



AP-230PH/AP-300PH  
Air Purifiers



Air Purifier with  
PlasmaTRUE™ Technology

### Questions or Concerns?

#### www.fellowes.com

- Troubleshooting
- Registration
- Manuals

#### Customer Service & Support

- Troubleshooting
- Replacement parts
- General questions

Canada	+1-800-665-4339
Mexico	+1-800-234-1185
United States	+1-800-955-0959



**Fellowes** 1789 Norwood Avenue, Itasca, Illinois 60143-1095 • USA • 630-893-1600

www.fellowes.com

© 2011 Fellowes, Inc. Part No. 869011

Fellowes® Air Purifier with  
PlasmaTRUE™ Technology Operator's Manual  
Please read these instructions before use.  
Do not discard: keep for future reference.

## TABLE OF CONTENTS

Warranty.....	2	Display Panel .....	7
Package Contents .....	2	Operation.....	8
Safety Instructions.....	3	Care and Maintenance.....	9-10
Product Specifications.....	4	Troubleshooting .....	11
Air Purifier Features.....	5		
Air Purifier Set-Up.....	6		

## LIMITED PRODUCT WARRANTY

Limited Warranty: Fellowes, Inc. ("Fellowes") warrants the parts of the machine to be free of defects in material and workmanship and provides service and support for 5 years from the date of purchase by the original consumer. If any part is found to be defective during the warranty period, your sole and exclusive remedy will be repair or replacement, at Fellowes' option and expense, of the defective part. This warranty does not apply in cases of abuse, mishandling, failure to comply with product usage standards, operation using an improper power supply (other than listed on the label), or unauthorized repair. Fellowes reserves the right to charge the consumers for any additional costs incurred by Fellowes to provide parts or services outside of the country where the air purifier is initially sold by an authorized reseller. ANY IMPLIED WARRANTY, INCLUDING THAT OF MERCHANTABILITY OR FITNESS FOR A PARTICULAR PURPOSE, IS HEREBY LIMITED IN DURATION TO THE APPROPRIATE WARRANTY PERIOD SET FORTH ABOVE. In no event shall Fellowes be liable for any consequential or incidental damages attributable to this product. This warranty gives you specific legal rights. The duration, terms, and conditions of this warranty are valid worldwide, except where different limitations, restrictions, or conditions may be required by local law. For more details or to obtain service under this warranty, please contact us or your dealer.

## PACKAGE CONTENTS

- Fellowes® Air Purifier with PlasmaTRUE™ Technology
- True HEPA Filter (1 filter)
- Carbon Filter (1 filter)
- Operator's Manual

## TROUBLESHOOTING

### Before you call

#### Solutions to Common Problems

Review this list before you call for service. This list covers problems that are not the result of defective materials or workmanship.

PROBLEM	POSSIBLE SOLUTION
The unit leaves smoke and odors in the air.	<ul style="list-style-type: none"> <li>• Make sure the sensor is not blocked or clogged.</li> <li>• Move the unit closer to the offending odors.</li> <li>• Replace the filters as needed.</li> </ul>
The unit seems to produce odors.	<ul style="list-style-type: none"> <li>• Replace the filters as needed.</li> </ul>
The air quality light is green, but there is still dust/odor in the air.	<ul style="list-style-type: none"> <li>• Clear the sensor with a vacuum cleaner, as it may be blocked or clogged.</li> </ul>
The air quality light is yellow or red, but the air seems clean.	<ul style="list-style-type: none"> <li>• Clear the sensor with a vacuum cleaner, as it may be blocked or clogged.</li> </ul>
Unit makes a ticking sound.	<ul style="list-style-type: none"> <li>• This indicates that the PlasmaTrue™ function is working.</li> </ul>
Unit interferes with radio or television reception.	<ul style="list-style-type: none"> <li>• Because this unit radiates radio frequency energy, we suggest you try one or more of the following: <ul style="list-style-type: none"> <li>- For better reception, adjust the television/radio antenna.</li> <li>- Move the unit away from the affected television/radio.</li> <li>- Plug the unit power cord into an outlet different from the television/radio power cord.</li> </ul> </li> </ul>
The FILTER REPLACEMENT indicator remains lit after replacing the True HEPA and/or Carbon Filter.	<ul style="list-style-type: none"> <li>• With the power on, press the FILTER REPLACEMENT button and hold for 3-5 seconds or until the unit light turns off.</li> </ul>

4. Place the new filters in the main unit. (HEPA Filter should always be inserted first, then the Carbon filter.)

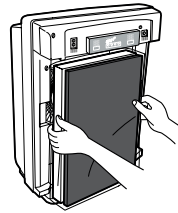

5. To reset the filter light once a new True HEPA and/or Carbon Filter is installed:
- Plug the unit back in with the front cover off.
  - Turn on the unit.
  - Locate the filter replacement button on the display panel.
  - Press and hold the filter replacement button for 3-5 seconds. A short beep will be heard and the light should turn off.
  - Place the front panel on the unit and the air purifier is ready to use.

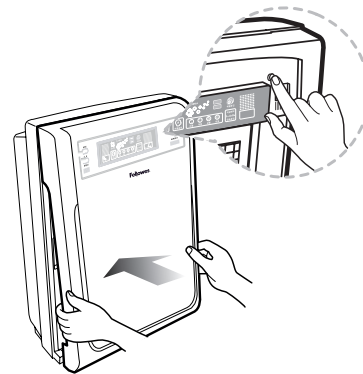

#### Air Quality Sensor Cleaning

Lightly vacuum the air quality sensor every two months after removing the front panel.

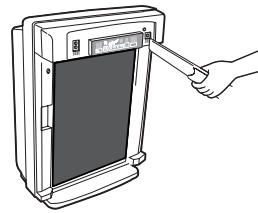

## SAFETY INSTRUCTIONS

Thank you for purchasing a Fellowes® Air Purifier. Please read this manual carefully before using. This product is for indoor use only.

### IMPORTANT CAUTIONS AND INSTRUCTIONS FOR USING YOUR AIR PURIFIER

**WARNING:** Follow the instructions in this manual to reduce the risk of electric shock, short circuit, and/or fire:

- Do not repair or modify the unit unless specifically recommended in this manual. All repairs should be completed by a qualified technician.
- The plug for this unit is polarized with one blade wider than the other. Do not force the plug into an electrical outlet.
- Do not alter the plug in any way. If the plug does not fit into the outlet, reverse the plug. If it still does not fit, contact a qualified technician to install a proper outlet.
- Do not use if the power cord or plug is damaged or the connection to the wall outlet is loose.
- Use AC 120V only.
- Do not damage, break, forcefully bend, pull, twist, bundle, coat, pinch, or place heavy objects on the power cord.
- Periodically remove dust from the power plug. This will reduce the chance that humidity will accumulate, which increases the risk of electric shock.
- If the power plug is damaged, it must be replaced by the manufacturer or a qualified technician.
- Remove the power plug from the outlet before cleaning the unit. When removing the power plug, grasp by holding the plug

itself, never hold by the cord.

- Remove the power plug from the outlet when the unit is not in use.
- Do not handle the power plug with wet hands.
- Do not operate the unit when using indoor smoke-generating insecticides.
- Do not clean unit with benzene or paint thinner. Do not spray insecticides on the unit.
- Do not use the unit where it is humid or where the unit may get wet, such as in a bathroom.
- Do not insert fingers or foreign objects into the air intake or outlet.
- Do not use the unit near flammable gases. Do not use near cigarettes, incense, or other spark-creating items.
- Unit will not remove carbon monoxide emitted from heating appliances or other sources.
- Do not block the intake or outlet vents.
- Do not use near hot objects, such as a stove. Do not use where the unit may come into contact with steam.
- Do not use the unit on its side.
- Keep away from products that generate oily residue, such as a deep fryer.
- Do not use detergent to clean the unit.
- Do not operate without a filter.
- Do not wash and reuse the True HEPA Filter.

PRODUCT SPECIFICATIONS		
	AP-230PH	AP-300PH
Room Area Served	230 sq. ft.	300 sq. ft.
Power Supply	AC 120V/60Hz	AC 120V/60Hz
Power Rate	Low 6W, Turbo 50W	Low 6W, Turbo 70W
Fan Speed	4 Speeds	4 Speeds
Display	LED Digital	LED Digital
Control Type	Auto/Manual	Auto/Manual
Air Quality Sensor	Yes	Yes
Filters	1 True HEPA Filter 1 Carbon Filter	1 True HEPA Filter 1 Carbon Filter
Cleaning System	Sanitized™ Carbon Filter True HEPA Filter PlasmaTrue™	Sanitized™ Carbon Filter True HEPA Filter PlasmaTrue™
CADR	150/161/156 (Smoke/Dust/Pollen)	191/200/201 (Smoke/Dust/Pollen)
Color	Metallic Silver and White	Metallic Silver and White
Dimensions	13.8"(W) X 9.1"(D) X 18.5"(H)	16.5"(W) X 9.8"(D) X 21.9"(H)
Weight	14 lbs	19 lbs

FILTER SPECIFICATIONS		
True HEPA Filter Replacement	9370001	9370101
Carbon Filter Replacement	9372001	9372101

#### INFORMATION TO THE USER

This equipment has been tested and found to comply with the limits for Class B digital device, pursuant to part 15 of the FCC Rules. These limits are designed to provide reasonable protection against harmful interference in a residential installation. This equipment generates, uses and can radiate radio frequency energy and, if not installed and used in accordance with the instructions, may cause harmful interference to radio communications. However, there is no guarantee that interference will not occur in a particular installation. If this equipment does cause harmful interference to radio or television reception, which can be determined by turning the equipment off and on, the user is encouraged to try to correct the interference by one more of the following measures:

- Reorient or relocate the receiving antenna
- Increase the separation between the equipment and receiver.
- Connect the equipment into an outlet on a circuit different from that to which the receiver is connected.
- Consult the dealer or an experienced radio/TV technician for help.

#### Warning

Any changes or modifications not expressly approved by the manufacturer could void the user's authority to operate the equipment.

## CARE AND MAINTENANCE

#### CLEANING

- Clean unit as necessary by wiping with a dry, soft cloth; for stubborn stains, use a warm, damp cloth.
- Do not use volatile fluids such as benzene, paint thinner, or scouring powder, as they may damage the unit surface.
- Keep the unit dry.
- Clean the wall behind the air outlet periodically, as it may become dirty.

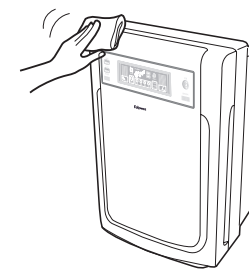

#### Filter Replacement

The replacement filter indicator will signal when to replace the True HEPA Filter and/or Carbon Filter. The replacement period will vary depending on the hours of use, air quality, and location of the unit. However, most True HEPA filters in normal use need to be replaced annually, and Carbon Filters every 3 months.

Do not wash and reuse the True HEPA or Carbon Filters—they will not work effectively.

**WARNING:** Before replacing any filters, make sure to remove the power plug from the wall outlet.

#### Replacement Procedure

1. Remove the front panel by grasping the bottom outside edges and gently pulling toward you.

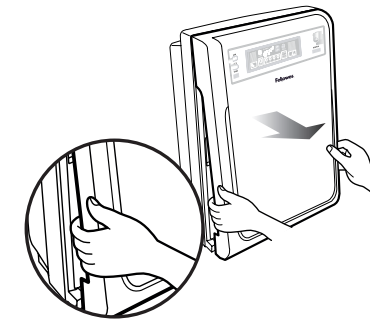

2. Pull out the filters that need to be changed.

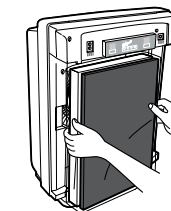

3. Remove any packaging wrap from the new filter(s).

For replacement filters, see page 4.

## OPERATION

### AUTOMATIC OPERATION

The unit is set to default to automatic operation when it is first turned on. The air purifier will automatically sense the amount of impurities in the air, and adjust the fan speed to keep your air purified.

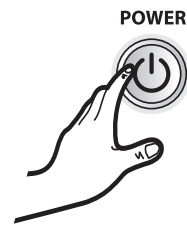

### MANUAL OPERATION

After you turn on the unit, you can switch to manual operation by using “+” and “-” buttons on the unit to control fan speed. To go back to auto, press “-” several times.

#### • LOW, MEDIUM, OR HIGH

These levels are recommended for standard daytime use. HIGH will activate automatically when sensors detect poor air quality.



LOW



MEDIUM



HIGH

#### • TURBO

The TURBO level, the highest fan speed, can be activated manually for maximum air purification.



TURBO

#### • AIR QUALITY LIGHT INDICATOR

Air Quality light indicator shows levels of air quality.



Green level indicates air is clean.

Yellow level indicates air quality is poor.

Red level indicates high level of pollutants in the air.

## AIR PURIFIER FEATURES

#### • Ultra-Quiet Operation

This Fellowes Air Purifier has a four-speed fan with ultra-quiet operation that is ideal for daytime or nighttime operation.

#### • Easy Maintenance

Fellowes Air Purifiers are simple and economical to maintain. For optimum performance, replace the True HEPA Filter when HEPA Filter life indicator has reached the RED level, or every 12 months. Change the carbon filter when the Carbon Filter light illuminates red or every 3 months.

#### • Air Quality Sensors

This air purifier is equipped with a digital sensor that automatically monitors air quality. As air quality levels change, fan speeds will adjust automatically when machine is set-up in “auto” mode.

#### • Four-Speed Setting

From LOW for quiet, energy-efficient operation to TURBO for the most effective cleaning.

#### • Replacement Filter Indicator Lights

Indicate when to replace the True HEPA Filter and Carbon Filter, depending on usage.

#### FOUR-STAGE PURIFICATION SYSTEM

Removes 99.97% of airborne pollutants.

#### • Carbon Filter

Removes odors and captures large airborne particulates.

#### • Sanitized™

Effectively reduces the development of bacteria, fungi and dust mites on carbon filter.

#### • True HEPA Filter

Captures 99.97% of particles and impurities as small as 0.03 microns, including mold spores, pollen, dust mites, most airborne microbes, allergens and cigarette smoke.

#### • PlasmaTRUE™ Technology

In the final stage of purification, Fellowes® PlasmaTRUE™ Technology safely removes airborne pollutants at the molecular level, instantly neutralizing viruses and bacteria in the air.

FRONT SIDE

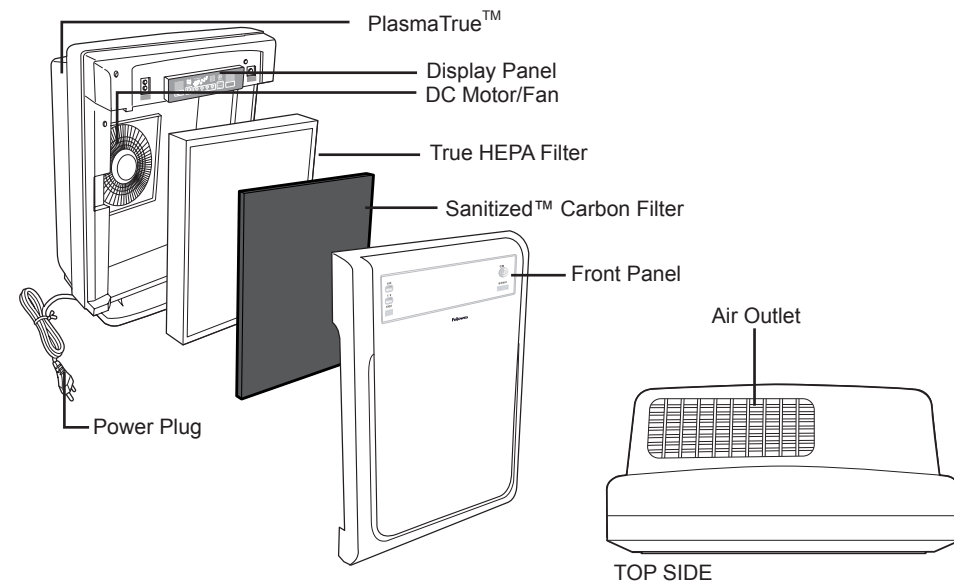

TOP SIDE

## AIR PURIFIER SET-UP

**NOTE:** Follow these instructions for best results.

- Place unit at least 2 feet from the wall.
- Keep unit away from drafty areas.
- Keep curtains away from unit, as they may interfere with air intake/outlet.
- Place unit on a stable surface with plenty of air circulation.

1. Remove protective film from the control panel.

2. Remove the front panel by grasping the bottom outside edges and gently pulling toward you.

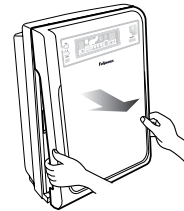

3. Pull out the filter packages and remove sealed plastic wrap.

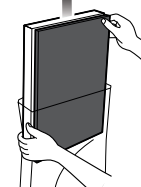

4. Return the filters to the unit, inserting the True HEPA first with the arrow pointing toward the back of the unit and then insert the carbon filter. (See page 10)

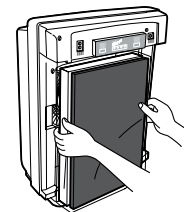

5. Replace the front panel by hooking the front panel on the top of the unit. Swing panel in by pushing gently until the panel snaps into place.



6. Plug in the power cord to a wall outlet.

7. Press POWER button until short “beep” is heard.

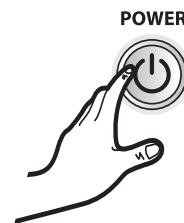

For the first 4 minutes after turning the unit on, the indicators will flash while the unit measures air quality.

## DISPLAY PANEL AP-230PH/AP-300PH

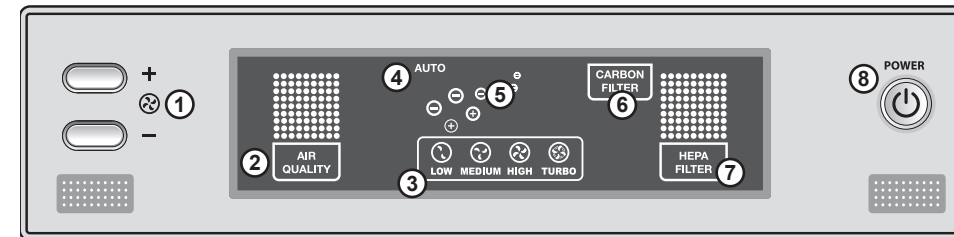

1. **MANUAL FAN SPEED ADJUSTMENT** - Press the + or – buttons to manually adjust fan speed to low, medium, high, turbo or auto speed.

2. **AIR QUALITY LIGHT INDICATOR** - Green, yellow, and red lights indicate the purity of your air.

3. **FAN SPEED INDICATOR** - Shows current fan speed setting: low, medium, high or turbo speed.

4. **AUTO MODE** - The unit is set to default to automatic operation when it is first turned on. Air purity sensor monitors the air and automatically adjusts the fan speed to keep your air purified. To go back to auto at any time, press “–” several times until auto lights up.

5. **PLASMATRUE™ TECHNOLOGY** - Safely removes airborne pollutants at the molecular level instantly neutralizing viruses and bacteria in the air. Light indicators show PlasmaTRUE™ Technology in action!

6. **CARBON FILTER CHANGE INDICATOR** - The red indicator light will signal when to replace filter. (Recommended to replace filter every three months under normal usage conditions.) For replacement filters, see page 4.

7. **TRUE HEPA FILTER CHANGE INDICATOR** - Green, yellow and red light indicate when to replace filter. The red indicator lights will signal when to replace filter. (Recommended to replace filter every twelve months under normal usage conditions.) For replacement filters, see page 4.

8. **POWER BUTTON** - This unit is set to default to automatic operation when it is first turned on. The air purifier will automatically sense the amount of impurities in the air, and adjust the fan speed accordingly.